

Insertion into *Aspergillus nidulans* of functional UDP-GlcNAc: α 3-D-mannoside β -1,2-N-acetylglucosaminyltransferase I, the enzyme catalysing the first committed step from oligomannose to hybrid and complex N-glycans

INGE KALSNER^{1,2}, WILL HINTZ^{2*}, LORNE S. REID^{2‡} and HARRY SCHACHTER^{1,3§}

¹ Research Institute, Hospital for Sick Children, 555 University Avenue, Toronto, Ont. M5G 1X8, Canada

² Allelix Biopharmaceuticals Inc., 6850 Goreway Drive, Mississauga, Ont. L4V 1P1, Canada

³ Department of Biochemistry, University of Toronto, Toronto, Ont. Canada

Received 26 April 1994, revised 10 January 1995

Filamentous fungi are capable of secreting relatively large amounts of heterologous recombinant proteins. Recombinant human glycoproteins expressed in this system, however, carry only carbohydrates of the oligomannose type limiting their potential use in humans. One approach to the problem is genetic engineering of the fungal host to permit production of complex and hybrid N-glycans. UDP-GlcNAc: α 3-D-mannoside β -1,2-N-acetylglucosaminyltransferase I (GnT I) is essential for the conversion of oligomannose to hybrid and complex N-glycans in higher eukaryotic cells. Since GnT I is not produced by fungi, we have introduced into the genome of *Aspergillus nidulans* the gene encoding full-length rabbit GnT I and demonstrated the expression of GnT I enzyme activity at levels appreciably higher than occurs in most mammalian tissues. All the GnT I activity in the *Aspergillus* transformants remains intracellular suggesting that the rabbit trans-membrane sequence may be capable of targeting GnT I to the fungal Golgi apparatus.

Keywords: fungi, *Aspergillus*, N-acetylglucosaminyltransferase I, glycoprotein synthesis, N-glycans

Abbreviations: CM, complete medium; Gal-T, UDP-Gal:GlcNAc β -1,4-galactosyltransferase (EC 2.4.1.38/90); GnT I, UDP-GlcNAc: α 3-D-mannoside β -1,2-N-acetylglucosaminyltransferase I (EC 2.4.1.101); HPLC, high performance liquid chromatography; M₃-octyl, Man α 1-6[Man α 1-3]Man β -octyl; PAGE, polyacrylamide gel electrophoresis; MES, 2-(N-morpholino)ethane sulfonate; PCR, polymerase chain reaction; PEG, polyethylene glycol; PMSF, phenyl methyl sulfonyl fluoride; SDS, sodium dodecyl sulfate; SSC (1 \times), 0.15 M NaCl/0.015 M sodium citrate (pH 7.0); STC, 1.2 M sorbitol, 100 mM Tris-HCl, pH 7.4, and 10 mM CaCl₂; STET, 0.1 M NaCl, 10 mM Tris-HCl, pH 8.0, 1 mM EDTA, pH 8.0, 5% Triton-X-100.

Introduction

Recombinant DNA technology is the present method of choice for the commercial production of human proteins for therapeutic use. Many of these proteins, such as growth factors, cytokines and protein hormones, are secretory proteins and may undergo post-translational modifications during their progress through the human secretory apparatus, e.g. proteo-

lytic processing, disulfide bond formation or glycosylation. These modifications are usually essential for correct protein folding and biological activity. High expression levels of recombinant proteins can be achieved using prokaryotic expression systems such as *Escherichia coli* but the products may be produced with aberrant disulfide bonds or other changes such as modified amino-terminal sequences [1, 2]. Moreover bacteria often produce inactive inclusion bodies and do not perform certain post-translational modifications such as glycosylation thereby limiting their use as expression hosts [1]. Eukaryote hosts are therefore preferable for the production of recombinant proteins for administration to humans.

* Present Address: Department of Biology, University of Victoria, Victoria, BC, Canada.

‡ Deceased. This paper is dedicated to the memory of Lorne S. Reid.

§ To whom enquiries should be addressed.

Yeast, fungal and insect cell hosts can produce large amounts of recombinant protein at lower costs compared to mammalian cell hosts. *Saccharomyces cerevisiae* has been used as an eukaryotic expression host for the production of both intracellular and secreted foreign proteins [3]. Although the intracellular expression rates for some heterologous proteins in *Saccharomyces cerevisiae* are high, yields are much lower for secreted products. Filamentous fungi, in particular strains of the genera *Aspergillus*, *Penicillium* and *Trichoderma*, are valuable alternative eukaryotic hosts because they are able to secrete large quantities of proteins and fermentation techniques have been developed for the industrial production of many fungal enzymes at levels as high as 20–30 g per litre, e.g. cellulases, (gluco)amylases, pectinases and proteases [4–8]. These organisms, in particular fungi of the genus *Aspergillus*, are therefore attractive expression hosts for the production of heterologous proteins, e.g. bovine chymosin [5, 9, 10]. A number of human proteins with pharmacological potential have been expressed in *Aspergillus*, including epidermal growth factor (EGF), growth hormone (hGH), interleukin-6 (IL-6), tissue plasminogen activator (tPA), α -2 interferon (IFN α 2), corticosteroid binding globulin (CBG), granulocyte colony stimulating factor (hGCSF), α -1 anti-trypsin and lactoferrin (hLF) ([4, 5, 11–14] and references therein).

Many of these proteins in their natural states contain relatively large amounts of complex N-glycans. However, recombinant glycoproteins produced in yeast, fungal and insect cell hosts contain primarily N-glycans of the oligomannose type [15–30]. In order to take full advantage of the *Aspergillus* expression system it would be desirable to produce glycoproteins which contain carbohydrate structures as similar as possible to those of the natural product. As a first step towards achieving this goal, we have inserted into *Aspergillus nidulans* a functional gene encoding UDP-GlcNAc: α 3-D-mannoside β -1,2-N-acetylglucosaminyltransferase I (GnT I; EC 2.4.1.101), an enzyme essential for the production of complex N-glycans.

The synthesis of the N-glycan moiety of glycoproteins produced in higher eukaryotic cells involves processing by a number of glycosyltransferases and glycosidases located in the cis-, medial- and trans-Golgi cisternae. GnT I catalyses a key reaction in this process, the transfer of a GlcNAc residue in β 1-2 linkage to the Man α 1-3 arm of the Man5-oligosaccharide precursor:

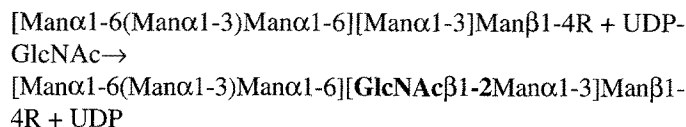

where R is GlcNAc β 1-4(+/-Fuc α 1-6)GlcNAc-Asn-polypeptide. This reaction provides an essential substrate for several subsequent enzymes involved in the formation of hybrid and complex N-glycan chains and is the first committed step in the conversion of oligomannose to hybrid and complex N-glycans [31, 32]. Since GnT I, and probably other N-glycan processing

enzymes, are not expressed in *Aspergillus*, recombinant glycoproteins produced in this host usually carry carbohydrate structures that are different from their natural counterparts.

The genes for rabbit [33, 34], human [35, 36], mouse [37, 38], rat [39] and chicken [40] GnT I have been cloned. GnT I is a medial-Golgi-localized type II transmembrane protein [41, 42] with a short amino-terminal cytoplasmic tail, a transmembrane signal/anchor region, a neck or stem region and a large intra-luminal carboxy-terminal catalytic domain, similar to all other cloned glycosyltransferases [43, 44]. The transmembrane domain is essential for targeting to and insertion into the Golgi membranes [41, 42]. In the hope that the mammalian targeting sequence in rabbit GnT I would also serve to insert GnT I into the Golgi membranes of *Aspergillus nidulans*, we have transformed these fungal cells with the gene for full length rabbit GnT I. We report in this paper that the transformed *Aspergillus* cells express relatively large amounts of functional intracellular GnT I. However, we have not been able to demonstrate the formation of complex N-glycans in this transformed fungal host. Furthermore, there is no information available on the presence in *Aspergillus nidulans* of the N-glycan processing α -mannosidases required to form the Man5-oligosaccharide substrate for GnT I. This report therefore represents only the first step towards the remodelling of *Aspergillus nidulans* for the production of glycoproteins suitable for use in humans.

Materials and Methods

Materials

The source of materials was as follows: UDP-N-[¹⁴C]acetyl-D-glucosamine was synthesized as previously described [45] and diluted with non-radioactive UDP-GlcNAc from Sigma; UDP-Gal-[6-³H] (American Radiolabeled Chemicals Inc., ART-131, 15 Ci/mmol⁻¹); Man α 1-6[Man α 1-3]Man β -octyl (M₃-octyl) was supplied by Dr Hans Paulsen, University of Hamburg, Hamburg, Germany [46, 47]; Sep-Pak C18 reverse phase cartridges (Waters); AG1-X8 (100–200 mesh, chloride form) (Bio-Rad); Protein G-Sepharose, T4 ligase (Pharmacia); restriction endonucleases (New England Biolabs); Triton X-100, GlcNAc, donkey anti-sheep IgG coupled to alkaline phosphatase (Sigma); Endo- β -N-acetylglucosaminidase H and UDP-Gal:GlcNAc-R β -1,4-galactosyltransferase (Boehringer-Mannheim); polyclonal antibody raised in sheep against purified recombinant rabbit GnT I fusion protein expressed in *E. coli* [41] (kind gift from D s.Jo Burke and Paul Gleeson, Melbourne, Australia); rabbit polyclonal antibody raised against *Aspergillus* glucoamylase (kind gift from Dr Zi-Min Guo, Allelix Biopharmaceuticals, Toronto); oligonucleotides were synthesized on a DNA synthesizer (Applied Biosystems, Model 391) and purified by the cartridge method; plasmid pTZ18R was obtained from Pharmacia; pAlcA1SLSphI derived from pEC2.2 [48], pGKIL6T encoding glucoamylase and pAN7-1 coding for hygromycin resistance [49], were provided by Dr Zi-Min Guo (Allelix Biopharmaceuticals, Toronto,

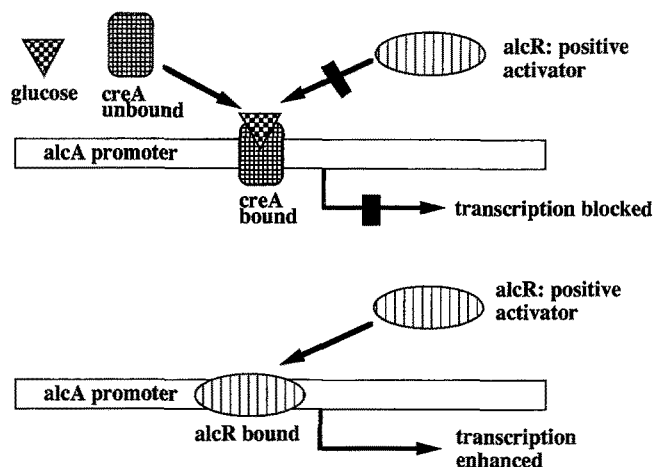

Figure 1. The T580 *Aspergillus nidulans* expression system [4, 48]. The expression system utilizes the promoter and transcriptional regulatory sequences derived from the alcohol dehydrogenase I (*alcA*) gene of *A. nidulans*. Transcription of the *alcA* gene is repressed in the presence of glucose due to a complex between glucose and the protein creA which blocks access of alcR to the *alcA* promoter. Transcription of the *alcA* gene is induced by ethanol, or other related metabolites, under glucose-depleted conditions. The T580 host is a uridine auxotroph (*ura*⁻) which contains multiply integrated copies of the *alcR* gene encoding a positively acting transcriptional regulatory factor for the *alcA* gene. The host has been tailored for the high level expression of multiply integrated copies of heterologous gene constructs driven by the *alcA* promoter. This dual control allows growth and protein production to be separated. The host *Aspergillus* strain is first cultured in the presence of glucose to maximize biomass followed by production of the desired protein under glucose-depleted conditions in the presence of threonine as inducer. The host overproduces the *alcR* gene product allowing expression of multiply inserted constructs driven by the *alcA* promoter region. This expression system is ideal for recombinant proteins that are susceptible to proteases or that may inhibit growth of the host.

Canada). Glucose assay solution (containing glucose oxidase) was obtained from a Boehringer-Mannheim kit (Automated Analysis Boehringer-Mannheim, Glucose).

Aspergillus strains

The *Aspergillus nidulans* expression host T580 was developed at Allelix Biopharmaceuticals Inc., Toronto, and is a derivative of strain FGSC4 (Fungal Genetics Stock Center) which has been tailored for the high level expression of multiply integrated copies of heterologous gene constructs driven by the *alcA* promoter region. The T580 host is a uridine auxotroph (*ura*⁻) which contains multiply integrated copies of the *alcR* gene encoding a positively acting transcriptional regulatory factor for the *alcA* gene. Transcription of the *alcA* gene is repressed in the presence of glucose due to a complex between glucose and the protein creA which blocks access of alcR to the *alcA* promoter. Transcription of the *alcA* gene is induced by ethanol, or other related metabolites, under glucose-

depleted conditions. Using this dual control, the host *Aspergillus* strain is first cultured in the presence of glucose to maximize biomass followed by production of the desired protein under glucose-depleted conditions in the presence of threonine as inducer (Fig. 1). The host overproduces the *alcR* gene product allowing expression of multiply inserted constructs driven by the *alcA* promoter region [48].

Media and growth conditions

The following stock solutions were used in media preparation: 100 × salt solution contains, in 1 l, KCl (52 g), MgSO₄·7H₂O (52 g), KH₂PO₄ (152 g); vitamin solution contains, in 1 l, putrescine (2.5 g), p-aminobenzoic acid (0.4 g), thiamine (0.05 g), biotin (0.001 g), inositol (0.4 g), calcium D-pantothenate (0.2 g), pyridoxine (0.25 g), choline chloride (1.4 g), nicotinic acid (0.1 g); trace elements solution contains, in 1 l, Na₂B₄O₇·10H₂O (0.04 g), CuSO₄·5H₂O (0.4 g), MnSO₄·4H₂O (0.8 g), Fe³⁺PO₄·H₂O (0.8 g), Na₂MoO₄·2H₂O (0.8 g), ZnSO₄·7H₂O (8.0 g); adenine solution contains 7.5 g adenine per l.

The complete medium (CM) contains, in 1 l, glucose (10 g), peptone (2 g), yeast extract (1 g), casamino acids (1.5 g), trace elements solution (1 ml), vitamin solution (10 ml), 100 × salt solution (10 ml), adenine solution (10 ml) and 0.05% Na deoxycholate. The minimal medium with 0.1 M threonine (YFT) contains, in 1 l, 100 × salt solution (10 ml), trace elements solution (1 ml), NaNO₃ (6 g), yeast extract (5 g), fructose (2 g), threonine (12 g) and 0.3% sodium alginate. Transformants were grown in CM to maximize biomass and were then transferred to YFT to induce enzyme expression. DNA was prepared from non-induced cells and extracts for enzyme assay were prepared from induced cells. Transformation converts the cells from *ura*⁻ to *ura*⁺ and allows selection in media lacking uridine. Uridine was added to the media to a concentration of 10 mM when non-transformed T580 (*ura*⁻) fungal cells were grown. Spores were generated by growing the fungus on CM agar (+/-uridine).

Construction of the *GnT I* expression cassette

Plasmid rc2500-pGEM7z (Fig. 2) with a cDNA insert which contains the entire open reading frame encoding rabbit GnT I [34] was used to obtain a construct for transformation of *Aspergillus*. The 5'-end of the gene was modified (Fig. 2) by polymerase chain reaction (PCR) amplification in order to introduce a *Sph* I restriction site at the ATG translational start signal. Plasmid rc2500-pGEM7z was used as template and the following deoxyoligonucleotides as PCR primers.

Forward primer:

5'-GGGGTTAAGCTTGCATGCTGAAGAAGCAGTCTGCTGGGCT-3'

Reverse primer:

5'-GGGGTTGAATTCCTGCAGTAGGCACCTCCAC-3'

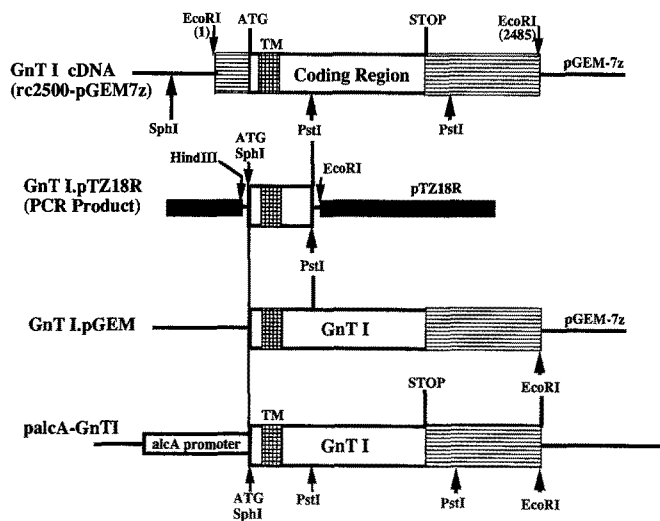

Figure 2. Construction of the palcA-GnTI plasmid used for transformation of *Aspergillus nidulans*. Plasmid rc2500-pGEM7z, with a cDNA insert which contains the entire open reading frame encoding rabbit GnT I, was modified by polymerase chain reaction (PCR) amplification in order to introduce a *Sph* I restriction site at the ATG translational start signal (see text). The PCR product was cut with *Hind* III and *Eco* RI and subcloned into the pTZ18R holding vector to produce plasmid GnTI.pTZ18R. The mutagenized DNA fragment was cut from GnTI.pTZ18R with *Sph* I and *Pst* I and ligated into *Sph* I/*Pst* I-cut rc2500-pGEM7z to produce plasmid GnTI.pGEM. The modified *GnT I* gene was cut out with *Sph* I and *Eco* RI and fused in frame to the *alcA* promoter in palcA1SL*Sph* I to produce plasmid palcA-GnTI.

The *Sph* I site to be inserted (GCATGC) is in italics in the forward primer, the *Hind* III (AAGCTT) and *Eco* RI (GAATTC) sites for subcloning into plasmid pTZ18R are in bold type in the forward and reverse primers respectively, and a *Pst* I site (CTGCAG) for subcloning back into plasmid rc2500-pGEM7z is in italics in the reverse primer. PCR amplification was carried out for 25 cycles [50]. The PCR product was purified by agarose gel electrophoresis, cut with *Hind* III and *Eco* RI, and the *Hind* III/*Eco* RI-tailed product was subcloned into the pTZ18R holding vector [51] to produce plasmid GnTI.pTZ18R (Fig. 2). Double-strand DNA sequencing was carried out by the dideoxy method [52] to verify the sequence. Plasmid rc2500-pGEM7z was digested with *Sph* I and partially digested with *Pst* I and the linearized plasmid lacking the shorter of the two *Sph* I/*Pst* I fragments (Fig. 2) was purified by agarose gel electrophoresis. Plasmid GnTI.pTZ18R was amplified and the mutagenized DNA fragment was cut out with *Sph* I and *Pst* I and ligated into *Sph* I/*Pst* I-cut rc2500-pGEM7z to produce plasmid GnTI.pGEM (Fig. 2). GnTI.pGEM was amplified and the modified *GnT I* gene was cut out with *Sph* I and *Eco* RI and fused in frame to the *alcA* promoter in palcA1SL*Sph* I to produce plasmid palcA-GnTI (Fig. 2). *Aspergillus nidulans* strain T580 was

then co-transformed with palcA-GnTI and the selectable marker gene *pFB94* (see below).

Transformation of *Aspergillus nidulans*

Protoplasting. Five hundred ml CM broth were inoculated with 1.5×10^8 spores and incubated overnight at 30°C with shaking (200 rpm). The mycelium was harvested onto sterile miracloth and rinsed with sterile water followed by 0.05 M maleate buffer containing 0.4 M MgCl₂, pH 5.8. Up to 5 g of mycelium (wet weight) were then digested with 250 mg lysing enzymes from *Trichoderma harizanum* (Sigma) in 500 ml 0.05 M maleate buffer, pH 5.8 containing 0.4 M MgCl₂. Incubation at 30°C with shaking at 200 rpm was carried out for about 2 h or until monitoring with a microscope showed that most of the mycelial clumps had been converted to protoplasts. The protoplast suspension was filtered through a sterile 100 µm nylon mesh. The filtrate was centrifuged in sterile tubes at 3000 rpm for 10 min at 4°C. The pellet was resuspended in ice-cold STC (containing 1.2 M sorbitol, 100 mM Tris-HCl, pH 7.4, and 10 mM CaCl₂) and centrifuged again. After the second washing step the protoplasts were resuspended in 0.5–1.0 ml cold STC adjusting to a protoplast concentration of 2×10^8 protoplasts per ml. This suspension was stored on ice for 8–12 h prior to transformation; long-term storage was at –70°C.

Transformation of protoplasts. Protoplasts (4×10^7 in 0.2 ml) were co-transformed with the palcA-GnTI vector (~5.0 µg) and the nutritional marker pFB94 (which contains the *pyr*/4 gene as a selectable marker; 0.5–1.0 µg) in 50 µl polyethylene glycol (PEG) 4000 (60% w/v) in 0.1 M Tris-HCl, pH 7.5, containing 1 µl β-mercaptoethanol and 10 mM CaCl₂. After incubation at room temperature for 20 min, an additional 2.5 ml PEG solution was added in small sequential aliquots and the mixture was incubated for another 20 min. The protoplast suspension was then sequentially diluted with 1 ml, 5 ml and 30 ml aliquots of STC and centrifuged (3000 rpm, 10 min, room temperature). The pellet was resuspended in CM broth (1.0 ml) containing 0.6 M sucrose and incubated at room temperature for 1 h. Aliquots (0.1 ml) of the transformed protoplasts were plated directly onto CM–sucrose agar. The plates were incubated at 30°C until sporulating colonies could be detected (about 4–5 days).

PCR screening of transformants

Following transformation spore suspensions ($2\text{--}4 \times 10^8$ spores per ml) were prepared from cultures grown from single conidia. CM broth (0.5 ml aliquots) was then inoculated with 0.1 ml of the spore suspension and incubated at 30°C overnight. The cultures were centrifuged in a microfuge for 10 min. The pellet was resuspended in 0.5 ml STET (0.1 M NaCl, 10 mM Tris-HCl, pH 8.0, 1 mM EDTA, pH 8.0, 5% Triton-X-100), boiled for 10 min and centrifuged. DNA was precipitated from the supernatant with ethanol and resuspended in sterile water. Dilutions of 1:10 and 1:100 were used as tem-

plates for PCR. The following temperature programme was used: two cycles at 94°C for 30 s, 50°C for 3 min and 72°C for 3 min followed by 30 cycles at 94°C for 30 s, 60°C for 30 s and 72°C for 3 min. The deoxyoligonucleotides used for the construction of GntI.pTZ18R (Fig. 2 and above) were used as PCR primers.

Preparation of a double transformant producing Gnt I and glucoamylase

Protoplasts were prepared from Gnt I producing strain T580-22 and co-transformed with pGKIL6T encoding glucoamylase (kindly provided by Dr Zi-Min Guo, Allelix Biopharmaceuticals, Toronto) and pAN7-1 coding for hygromycin resistance [49]. Protoplasting and transformation were performed as described above. Transformants were selected by measuring the glucoamylase activity (see below). Glucoamylase-positive transformants were also assayed for Gnt I activity (see below). Only one double transformant (T580-22-GluA-14) out of 16 tested showed glucoamylase activity comparable to a glucoamylase-producing control strain G1712 (kindly provided by Dr Zi-Min Guo, Allelix Biopharmaceuticals, Toronto). T580-22-GluA-14 also had Gnt I activity comparable to the parent T-580-22 strain.

Southern blot analysis

Isolation of genomic DNA Fifty ml CM broth were inoculated with 2×10^7 spores and incubated for 16–24 h at 30°C. Mycelia were collected by filtration through miracloth and lyophilized overnight. Dried mycelia were ground to fine powder and about 100 mg were suspended in 2 ml of 50 mM EDTA/0.2% SDS and vortexed until fluid. After incubation at 65°C for 1 h the samples were centrifuged in a microfuge for 10 min and the supernatants transferred to Eppendorf tubes. Potassium acetate, 3 M at pH 4.8 (prepared by adding glacial acetic acid to 5 M potassium acetate until pH 4.8 is reached) was added at 1/6 volume and the tubes were incubated on ice for 30 min. After centrifugation the DNA was precipitated by adding an equal volume of isopropanol to the supernatant followed by incubation at room temperature for 5 min. DNA was pelleted by centrifugation, washed with 70% ethanol and resuspended in 0.3 ml TE buffer, pH 8.0.

The DNA samples were then treated with 0.06 ml DNase-free RNase A (10 mg ml^{-1}) followed by 0.08 ml proteinase K (10 mg ml^{-1}). The DNA solution was extracted twice with each of 1 volume phenol, 1 volume phenol-chloroform (1:1) and 1 volume chloroform. To the aqueous phase of the last chloroform extraction were added 1/2 volume of 7.5 M ammonium acetate and 1 ml ethanol. After incubation for 10 min at room temperature precipitated DNA was pelleted by centrifugation and washed with 70% ethanol. The dried pellet was redissolved in 0.05 ml of sterile water.

Southern blot analysis DNA (0.04 mg) was digested with *Afl* III and *Nar* I and the digests were subjected to agarose gel electrophoresis followed by Southern blotting using standard

procedures [51]. Prehybridization and hybridization of the Southern filters were performed in $5 \times \text{SSC}/1\% \text{ SDS}$ /salmon sperm DNA (0.1 mg ml^{-1}) at 65°C for 3 h and 18 h, respectively. The hybridization solution contained 50 ng of ^{32}P -labelled probe (specific activity $1.5 \times 10^5 \text{ dpm ng}^{-1}$). The probe was prepared from plasmid rc2500-pGEM7z by digestion with *Pst* I to generate a 1400 bp segment of DNA (Fig. 2) and was labeled by random priming with the T7 Quick Prime Kit (Pharmacia). Filters were washed in $2 \times \text{SSC}$ at room temperature for 30 min followed by $0.1 \times \text{SSC}/0.1\% \text{ SDS}$ at 65°C for 30 min and $0.1 \times \text{SSC}$ at room temperature for 45 min. The filters were exposed to X-ray film overnight at -80°C with an intensifying screen.

Gnt I assays

Transformants shown to contain the *Gnt* I gene by PCR analysis (see above) were grown in YFT broth for up to 52 h to induce expression of Gnt I activity. Mycelium was harvested and protoplasts were prepared as described above. Protoplasts ($\sim 1 \times 10^9$ particles per ml) were washed with water and then extracted with 1% Triton-X-100/0.1 mM PMSF (phenyl methyl sulfonyl fluoride); protein concentrations of the extracts were from 0.7–5.5 mg ml^{-1} . The reaction mixture in the enzyme assay [53] typically contained, in a total volume of 0.040 ml, 0.5–1.0 mM $\text{Man}\alpha 1 \rightarrow 6[\text{Man}\alpha 1 \rightarrow 3]\text{Man}\beta\text{-octyl}$ ($\text{M}_3\text{-octyl}$), 0.1 M MES, pH 6.1, 20 mM MnCl_2 , 0.05 mM UDP- ^{14}C]GlcNAc ($5500 \text{ dpm/nmol}^{-1}$) (or UDP- ^3H]GlcNAc at 50 000 dpm/nmol^{-1} for kinetic studies), 10 mM AMP, 0.2 M GlcNAc and enzyme extract (0.03–0.22 mg protein per assay). After incubation at 37°C for 2 h (screening of transformants) or 30 min (kinetic studies), the reaction was stopped with 1 ml 0.02 M sodium tetraborate/2 mM disodium EDTA. Purification of the product (screening of transformants) was done by passing the reaction mixture through a 1 ml column of AG 1-X8 (chloride form) equilibrated with water. The column was washed with 2 ml water and the radioactivity in the eluate was counted in 17 ml scintillation fluid. Product formation for the kinetic studies was assayed by adsorption to and elution from Sep-Pak C18 reverse-phase cartridges [54]. Values were corrected for radioactivity obtained in control incubations lacking acceptor substrate. Product formation under the conditions used for the kinetic studies is proportional to time of incubation and enzyme protein concentration. Kinetic constants were derived as previously described [55]. Protein concentration of the extracts was measured using the BCA Protein Kit from Pierce.

Glucoamylase assays

A 1% solution of rice starch, prepared by dissolution in boiling water, was cooled to room temperature and 0.2 ml were mixed with 0.2 ml buffer (0.2 M sodium acetate, pH 5.0) and 20–50 μl clear culture supernatant. Half of this reaction mixture was immediately mixed with 0.1 ml 0.2 M perchloric acid to serve as a control. The other half was incubated at 37°C for 30–45 min and 0.1 ml 0.2 M perchloric acid was added. Aliquots (20 μl) of each reaction and control solution were transferred to

a microtitre plate. Glucose assay solution (0.2 ml, containing glucose oxidase, Automated Analysis Boehringer-Mannheim, Glucose) was added to each well and the plate incubated at room temperature in the dark for 10 min. The plates were read at an absorbance of 495 nm on a Titertek plate reader. A glucose standard curve was run to calibrate the assay.

Immunoblot analysis of recombinant *GnT I*

Protoplast extracts were subjected to sodium dodecyl sulfate-polyacrylamide gel electrophoresis (SDS-PAGE) [56] under reducing conditions followed by immunoblot analysis (Western analysis). The gels were electrophoretically blotted onto nitrocellulose membranes. The membranes were probed with a sheep polyclonal antibody raised against a recombinant rabbit *GnT I* fusion protein expressed in *E. coli* [41]. The sheep antiserum was purified by 50% ammonium sulfate precipitation followed by adsorption to a column of Protein G-Sepharose, elution with 0.1 M glycine buffer at pH 2.5 and neutralization with 1.0 M Tris-HCl, pH 8.0. The sheep antibody was used at a 1:100 dilution and detected with donkey anti-sheep IgG coupled to alkaline phosphatase.

Product identification by HPLC

Standard oligosaccharides and enzyme product (purified on AG1 × 8 as described above) were separated by HPLC using a Waters system equipped with an automated gradient controller and an Alltech Econosil C₁₈ column (250 × 4.6 mm). The column was protected with a guard column filled with C₁₈ bound to silica. Samples were eluted isocratically with 19% acetonitrile in water at a flow rate of 1 ml min⁻¹. The absorbance at 195 nm was monitored and 2 ml fractions were collected and counted in 5 ml scintillation fluid in a scintillation counter.

Analysis of glucoamylase producing strains of *Aspergillus*

Supernatants from cultures of the double transformant T580-22-GluA-14 (see above) and the glucoamylase producing control strain G1712 (provided by Dr Zi-Min Guo, Allelix Biopharmaceuticals, Toronto) were concentrated using an Amicon ultrafiltration chamber. Aliquots (15–30 µl) from these supernatants were incubated in the absence or presence of endo-β-N-acetylglucosaminidase H (Boehringer-Mannheim) for 20–24 h at 37°C [57] and subjected to SDS-PAGE under reducing conditions with a 4–15% acrylamide gradient [56]. Gels were stained with Coomassie Blue or subjected to immunoblot analysis (Western analysis) by electrophoretic blotting onto nitrocellulose membranes. The membranes were probed with a rabbit polyclonal antibody raised against *Aspergillus* glucoamylase (kindly supplied by Dr Zi-Min Guo, Allelix Biopharmaceuticals, Toronto), as described above. The possible presence of terminal GlcNAc residues on *Aspergillus* glycoproteins was tested by measuring transfer into the protein fraction of radioactive Gal from UDP-Gal catalysed by UDP-Gal: GlcNAc β-1,4-galactosyl-transferase (Gal-T) [58]. Aliquots (2.5 to 5 µl) of concentrated supernatants from cultures of T580-22-GluA-14 and G1712

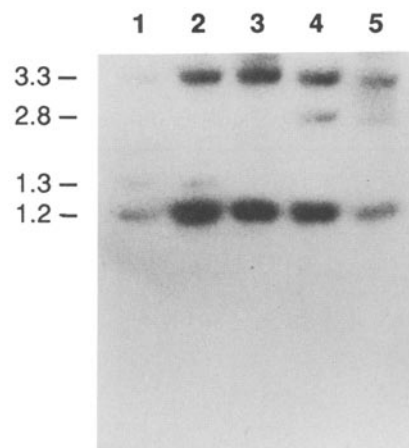

Figure 3. Southern blot analysis. DNA samples (0.04 mg) prepared from non-transformed and transformed fungi were digested with *Afl* III and *Nar* I and the digests were subjected to Southern blotting. The hybridization solution contained 50 ng of ³²P-labelled probe (specific activity 1.5 × 10⁵ dpm/ng⁻¹). The probe was prepared from plasmid rc2500-pGEM7z (Fig. 2) by digestion with *Pst* I to generate a 1.4 kb segment of DNA. Lanes 1 to 5 show blots for five positive transformants (clones 03, 06, 09, 19 and 22 respectively, Table 1). There were no bands at 1.2 and 3.3 kb visible with DNA from the non-transformed T580 cells (not shown). The positions of DNA standards are shown at the side of the radioautograph (in kb).

were mixed with 1 µl 0.1 M HEPES buffer, pH 8.0, 1 mU (1 mU = 1 nmol min⁻¹) Gal-T, 2 µl 0.84 mM UDP-Gal-[6-³H] (25 µCi, 15 Ci mmol⁻¹), 2 µl 0.1 M MnCl₂ and 0.1 µl PMSF and incubated for ~20 h at 37°C. The samples were then run on SDS-PAGE [56] with a 4–10% acrylamide gradient. The gel was fixed in acetic acid : methanol : water (1:5:5) and soluble radioactive material was removed with several washes in drying solution (5% glycerol:30% ethanol in water). The gel was dried and exposed to X-ray film (Kodak) for 1 week.

Results

Incorporation of the rabbit GnT I gene into the genome of Aspergillus nidulans

Heterologous expression of *GnT I* in *Aspergillus nidulans* was carried out with a full-length cDNA encoding rabbit *GnT I* [34]. The cDNA was inserted into the fungal expression vector *palcA*ISLSph I as described in the Methods section to yield the construct *palcA*-*GnT I* (Fig. 2). This expression vector utilizes the promoter and transcriptional regulatory sequences derived from the alcohol dehydrogenase I (*alcA*) gene of *A. nidulans* (Fig. 1). Protoplasts of the T580 (*ura*⁻) fungal strain were co-transformed with *palcA*-*GnT I* and pFB94 which contains the *pyr4* gene as a selectable marker. *Pyr4* encodes for orotidine-5'-phosphate decarboxylase which converts orotidine-5'-phosphate to uridine-5-phosphate [4, 59]. Since this

Table 1. GlcNAc-transferase I activity in *Aspergillus* protoplast extracts. Detergent extracts of non-transformed and transformed *Aspergillus* protoplasts were assayed for GlcNAc-transferase I activity as described in the text. Incubations were for 2 h at 37°C and UDP-[¹⁴C]GlcNAc (5500 dpm nmol⁻¹) was used as sugar donor.

Transformant	dpm per 2h	Protein assayed (mg)	nmol mg ⁻¹ per h
T580 (non transf.)	< 100	0.10	<0.1
T580-03	3387	0.06	5.1
T580-04	< 100	0.03	<0.3
T580-06	42 316	0.11	35
T580-09	40 763	0.10	37
T580-19	82 072	0.22	34
T580-22	67 884	0.13	47

enzyme is missing in the *ura*⁻ mutant, the only colonies which will grow on agar plates lacking uridine are those which have been successfully transformed. Transformants were purified twice through conidial spores.

Integration of the *GnT I* gene into the fungal genome was determined by PCR and Southern blot analysis of fungal DNA. Several transformants showed a 300 bp DNA band on PCR amplification using the primers described in the Methods section (data not shown); such a band is expected if the *GnT I* sequence is present in the genome. Southern blot analysis was performed by probing genomic DNA cut with *Afl* III and *Nar* I with a ³²P-labelled 1400 bp DNA fragment prepared from plasmid rc2500-pGEM7z by digestion with *Pst* I (Fig. 2). As shown in Fig. 3 two major radiolabelled bands were detected

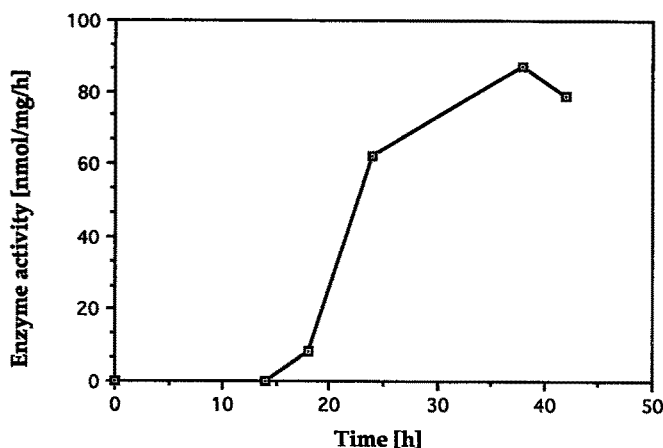

Figure 4. Time course of GnT I production. Since T580-22 extracts (Table 1) had the highest enzyme activity, this transformant was chosen for a time course study. Protoplasts were prepared at 14, 18, 24, 38, 42 and 48 h after start of culture and assayed for enzyme activity. The highest activity (over 80 nmol mg⁻¹ per h) was detected at 38 h of incubation. Samples taken after 42 h could not be checked for enzyme activity because protoplasts could no longer be generated.

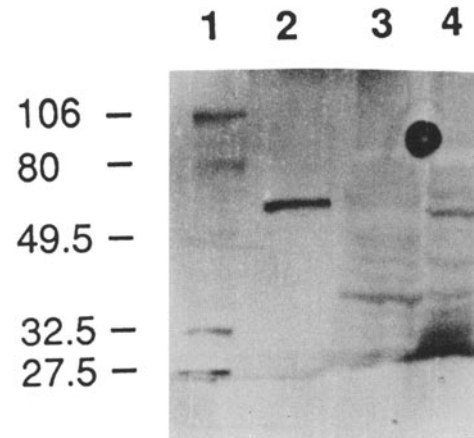

Figure 5. Immunoblot analysis. Protoplast extracts were subjected to SDS-PAGE under reducing conditions followed by immunoblot analysis. The membranes were probed with a sheep polyclonal antibody raised against a recombinant rabbit GnT I fusion protein. The sheep antibody was used at a 1:100 dilution and detected with donkey anti-sheep IgG coupled to alkaline phosphatase. Lane 1, protein standards (kDa are indicated); lane 2, a control sample of recombinant rabbit GnT I produced in the baculovirus/insect cell system [72]; lane 3, extract from non-transformed T580 cells; lane 4, extract from T580-22 cells.

in each transformant. The lower band (1200 bp) represents the *Afl* III-*Nar* I DNA fragment predicted from the sequence of the rabbit *GnT I* gene [34]. The upper band at 3300 bp represents the *Afl* III-*Nar* I fragment derived from the *Nar* I site near the 3'-end of the *GnT I* gene and the *Afl* III site at position 592 of the pTZ19R vector.

Expression of rabbit *GnT I* activity in *Aspergillus nidulans*

Transformants showing incorporation of GnT I DNA by PCR and Southern analysis were grown in YFT medium containing threonine as inducing agent. Protoplasts were assayed for GnT I activity. Non-transformed T580 cells did not show detectable enzyme activity indicating that wild type *Aspergillus nidulans* does not express GnT I. Several transformants, however, showed GnT I activities greater than 30 nmol mg⁻¹ h⁻¹ (Table 1). These levels are appreciably higher than those normally found in mammalian tissues [53, 55, 60, 61]. There was no detectable GnT I activity in the medium.

Since T580-22 extracts had the highest enzyme activity (47 nmol mg⁻¹ per h) this transformant was chosen for a time course study. A 300 ml culture was incubated for over 48 hours. Samples (25 ml) were taken after 14, 18, 24, 38, 42 and 48 h. Immediately after taking a sample the mycelia were protoplasted as described above and stored at 4°C until assayed for enzyme activity. As shown in Fig. 4 the highest enzyme activity was detected after 38 h incubation. Samples taken after 42 h could not be checked for enzyme activity because protoplasts could no longer be generated.

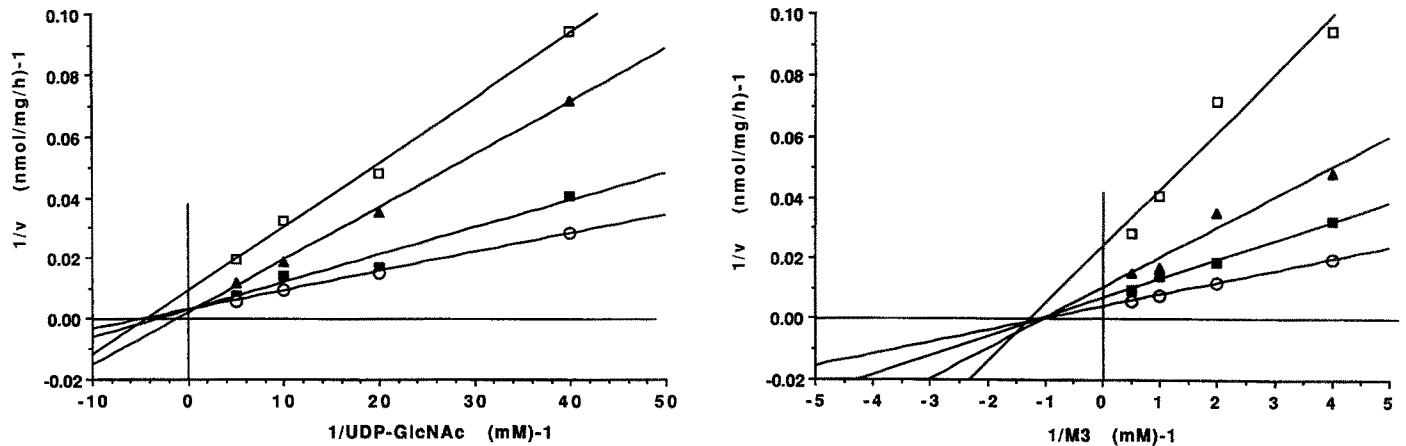

Figure 6. Kinetic analysis of recombinant GnT I. Protoplast extracts (0.010 ml at 1 mg ml⁻¹) prepared from transformant T580-22 (Table 1) were assayed for GnT I activity (see text) at varying concentrations of both M₃-octyl and UDP-[³H]GlcNAc (50 000 dpm/nmol⁻¹). Assays were carried out at 37° C for 30 min. Enzyme activities are expressed as nmol mg⁻¹ per h. (a) Reciprocal 1/v versus 1/S plots for UDP-GlcNAc at varying concentrations (mM) of M₃-octyl (□, 0.25; ▲, 0.5; ■, 1.0; ○, 2.0). (b) Reciprocal 1/v versus 1/S plots for M₃-octyl at varying concentrations (mM) of UDP-GlcNAc (□, 0.025; ▲, 0.05; ■, 0.1; ○, 0.2). The kinetic parameters calculated from these data are: V_{max}, 400 nmol mg⁻¹ per h; K_m values for M₃-octyl and UDP-GlcNAc, 0.8 and 0.2 mM respectively.

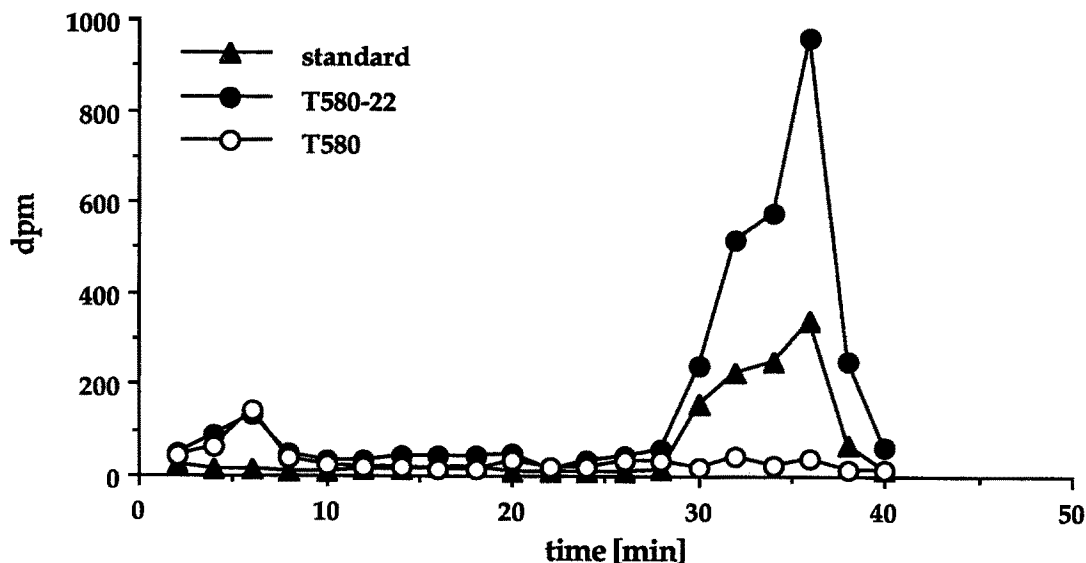

Figure 7. HPLC analysis of GnT I product. The reaction product of GnT I present in extracts of T580-22 protoplasts (●) coelutes with standard [¹⁴C]GlcNAc β1-2Manα1-3 (Manα1-6)Manβ-octyl [53] (▲) at 36 min. Extracts from T580 cells showed no product (○). HPLC conditions: flow rate, 1 ml min⁻¹; isocratic elution with 19% acetonitrile; 2 ml fractions.

Immunoblot analysis

Triton extracts of protoplasts from fungi expressing GnT I and control fungi (non-transformed T580 cells) were analysed by SDS-PAGE followed by immunoblotting. A band is seen at

about 52 kDa in the transformed cells (Fig. 5, lane 4) but is absent from the non-transformed controls (Fig. 5, lane 3). Some of the minor bands in lane 4 are also present in the non-transformed cells while others may be due to proteolysis. The

presence of proteases in the fungal extracts was indicated by the fact that if PMSF is not added to the protoplast extract, the yield of GnT I is considerably reduced.

Kinetic studies

All assays were carried out under conditions at which incorporation of GlcNAc into acceptor was proportional to enzyme concentration and time of incubation. Kinetic parameters were derived from reciprocal velocity-substrate plots (Fig. 6). The K_m values for M3-octyl and UDP-GlcNAc are, respectively, 0.8 and 0.2 mM, similar to previous values derived for GnT I from rabbit liver [55], bovine colostrum [60] and rat liver [53]. The V_{max} is about 400 nmol mg h⁻¹ per h.

Identification of the enzyme product by HPLC

To confirm the identity of the enzyme product with a well characterized standard (GlcNAc β 1,2Man α 1,3[Man α 1,6] Man β -octyl [53]), radioactive product was prepared as described under Materials and methods. The product was purified using AG1-X8, lyophilized and run on reversed phase HPLC. As shown in Fig. 7 the product of the recombinant enzyme co-elutes with the standard oligosaccharide at 36 min.

Analysis of glucoamylase producing strains of *Aspergillus*

The double transformant T580-22-GluA-14 produced GnT I at the same level as the parent strain T580-22 (Table 1) and glucoamylase at levels equivalent to a control glucoamylase producing strain G1712, i.e. 0.6 and 1.2 μ mol glucose per min per ml of culture supernatant from T580-22-GluA-14 and G1712 respectively. SDS-PAGE analysis (data not shown) was carried out on culture supernatants from these two strains using Coomassie Blue staining or immunoblotting with anti-glucoamylase antibody. Endo- β -*N*-acetylglucosaminidase H treatment caused similar shifts (\sim 2–3 kDa to lower molecular weights in the mobility of glucoamylase from both strains. Attempts to show Gal-T catalysed incorporation of radioactive Gal into *Aspergillus* glycoproteins were unsuccessful for both strains. Even prolonged (7 days) exposure of the dried SDS-PAGE gels to X-ray film showed no radioactive bands. Calculations based on the molecular weight of glucoamylase (68 000), the concentration of glucoamylase in the culture supernatants (about 20 μ g ml⁻¹) and the specific activity of UDP-Gal-[6-³H] (15 Ci mmol) indicate that it should have been possible to detect incorporation of radioactive Gal at 0.02 mol mol⁻¹ or higher.

Discussion

UDP-GlcNAc: α 3-D-mannoside β -1,2-*N*-acetylglucosaminyl-transferase I (GnT I) is essential for the conversion of oligomannose to hybrid and complex N-glycans in higher eukaryotic cells [31, 32]. It is a type II transmembrane protein targeted to the medial-Golgi by the transmembrane region [41]. GnT I activity has been demonstrated in mammalian [53,

55, 60], avian [61], insect [62] and plant [63–66] cells but does not appear to be present in fungi (Table 1; Fig. 7) or yeast [23, 26]. Yeast and fungi therefore only synthesize oligomannosidic glycan chains [14, 23, 26].

Several human proteins have already been expressed successfully in filamentous fungi (see Introduction). Many processing reactions proceed normally in fungal hosts. Recombinant human glycoproteins produced in fungi, however, carry only carbohydrates of the oligomannosidic type. Oligomannose N-glycans seem to occur more commonly with promoters which give relatively high yields [67]. These glycans are foreign to the mammalian body and may cause severe immunological reactions if administered to humans. Furthermore, most naturally occurring human glycoproteins carry complex N-glycans and, in some cases, these glycans contribute to the biological functions of the glycoproteins [68–71]. These factors present a serious disadvantage to the use of fungal expression systems for the production of recombinant glycoproteins for use in humans.

One approach to the problem is genetic engineering of the fungal host to permit production of complex and hybrid N-glycans. Since GnT I, the first committed step towards the production of these glycans, is not produced by fungi, we have undertaken the introduction of this enzyme into *Aspergillus nidulans*. We have introduced into the fungal genome the gene encoding full-length rabbit GnT I and demonstrated the expression of GnT I enzyme activity at levels appreciably higher than occurs in most mammalian tissues. Full length GnT I includes the transmembrane region which contains the information for targeting the protein to the mammalian Golgi apparatus [41]. All the GnT I activity in our *Aspergillus* transformants remains intracellular, there is no detectable enzyme activity in the supernatant and GnT I activity can only be measured after treating the lysed protoplasts with Triton X-100; this suggests that the mammalian trans-membrane sequence may be capable of targeting GnT I to the fungal Golgi apparatus. This latter point has, however, not as yet been established.

Even if GnT I in the fungal transformants is correctly targeted to the Golgi apparatus with the catalytic domain within the Golgi lumen, this alone does not ensure the production of complex N-glycans. Endo- β -*N*-acetylglucosaminidase H treatment of glucoamylase from the double transformant T580-22-GluA-14 showed the presence of the expected oligomannose N-glycans but no endo- β -*N*-acetylglucosaminidase H-resistant glycans were detected indicative of low or absent complex N-glycans. This was confirmed by the absence of Gal-T-dependent Gal incorporation. Many factors must operate for complex N-glycan synthesis to occur, e.g. proper transport of nucleotide-sugars into the Golgi lumen and the presence within the Golgi of processing enzymes such as the α -mannosidases required to convert oligomannose N-glycans to glycans with a Man α 1-3Man β 1-4GlcNAc-terminus, the substrate for GnT I. The synthesis of mammalian-type complex N-glycans also requires the presence of α -mannosidase II, UDP-GlcNAc: α 6-D-mannoside β -1,2-*N*-acetylglucosaminyl-

transferase II, galactosyltransferase, sialyltransferases and other glycosyltransferases. This study is therefore only a first step towards solving the problem of remodeling *Aspergillus* and much further work remains to be done.

Acknowledgments

This research was supported by the Protein Engineering Network Centres of Excellence (PENCE) of Canada. We would like to thank the following: Dr Mohan Sarkar, Hospital for Sick Children, Toronto, for plasmid rc2500-pGEM7z; Drs Peter Lagosky and Zi-Min Guo, Allelix Biopharmaceuticals, Toronto, for helpful critical discussions and advice in the construction and use of plasmid palcA-GnTI; Dr Zi-Min Guo for plasmid pGKIL6T, glucoamylase producing *Aspergillus* strain G1712 and rabbit polyclonal antibody raised against *Aspergillus* glucoamylase; Dr Hans Paulsen, University of Hamburg, Hamburg, Germany, for Man α 1-6[Man α 1-3]Man β -octyl; Drs Jo Burke and Paul Gleeson, Melbourne, Australia, for sheep anti-rabbit GnT I antibody.

References

- Gold L (1990) *Methods Enzymol.* **185**: 11–14.
- Kohno T, Carmichael DF, Sommer A, Thompson RC (1990) *Methods Enzymol.* **185**: 187–95.
- Emr SD (1990) *Methods Enzymol.* **185**:231–33.
- Gwynne DI, Devchand M (1992) *Biotechnology* **23**:203–14.
- van den Hondel CAMJJ, Punt PJ, van Gorcom RFM (1992) *Antonie Van Leeuwenhoek* **61**:153–60.
- Jeenes DJ, Mackenzie DA, Roberts IN, Archer DB (1991) *Biotechnol Gene. Eng Rev* **9**:327–67.
- Punt PJ, Zegers ND, Busscher M, Pouwels PH, Van den Hondel CAMJJ (1991) *J Biotechnol* **17**:19–34.
- Schechtman MG (1992) *Biotechnology* **23**:271–96.
- Cullen D, Gray GL, Wilson LJ, Hayenga KJ, Lamsa MH, Rey MW, Norton S, Berka RM (1987) *Biotechnology* **5**:369–76.
- Ward M, Wilson LJ, Kodama KH, Rey MW, Berka RM (1990) *Biotechnology* **8**:435–40.
- Ward PP, May GS, Headon DR, Conneely OM (1992) *Gene* **122**:219–23.
- Carrez D, Janssens W, Degrave P, van den Hondel CAMJJ, Kinghorn JR, Fiers W, Contreras R (1990) *Gene* **94**:147–54.
- Contreras R, Carrez D, Kinghorn JR, van den Hondel CAMJJ, Fiers W (1991) *Biotechnology* **9**:378–81.
- Upshall A, Kumar AA, Bailey MC, Parker MD, Favreau MA, Lewison KP, Joseph ML, Maraganore JM, McKnight GL (1987) *Biotechnology* **5**:1301–04.
- Davidson DJ, Castellino FJ (1991) *Biochemistry* **30**:6167–74.
- Flores-Carreón A, Hixson SH, Gómez A, Shao MC, Krudy G, Rosevear PR, Wold F (1990) *J Biol Chem* **265**:754–59.
- Hernandez LM, Ballou L, Ballou CE (1990) *Carbohydr Res* **203**:1–11.
- Herscovics A, Orlean P (1993) *Faseb J* **7**:540–50.
- Jarvis DL, Summers MD (1989) *Mol Cell Biol* **9**:214–23.
- Khanh NQ, Ruttkowski E, Leidinger K, Albrecht H, Gottschalk M (1991) *Gene* **106**:71–77.
- Knepper TP, Arbogast B, Schreurs J, Deinzer ML (1992) *Biochemistry* **31**:11651–59.
- Kuroda K, Geyer H, Geyer R, Doerfler W, Klenk H-D (1990) *Virology* **174**:418–29.
- Lehle L (1992) *Antonie Van Leeuwenhoek* **61**:133–34.
- Livi GP, Ferrara A, Roskin R, Simon PL, Young PR (1990) *Gene* **88**:297–301.
- Svoboda M, Przybylski M, Schreurs J, Miyajima A, Hogeland K, Deinzer M (1991) *J Chromatogr Biomed Appl* **562**:403–19.
- Tanner W, Lehle L (1987) *Biochim Biophys Acta* **906**:81–99.
- Townsend RR, Atkinson PH, Trimble RB (1991) *Carbohydr Res* **215**:211–17.
- Turnbull IF, Smith DR, Sharp PJ, Cobon GS, Hynes MJ (1990) *Appl. Environ. Microbiol.* **56**:2847–52
- Wathen MW, Aeed PA, Elhammer AP (1991) *Biochemistry* **30**:2863–68.
- Yu Ip CC, Miller WJ, Kubek DJ, Strang AM, Van Halbeek H, Pieszecki SJ, Alhadeff JA (1992) *Biochemistry* **31**:285–295.
- Schachter H (1986) *Biochem. Cell Biol.* **64**:163–81
- Schachter H (1991) *Glycobiology* **1**:453–61
- Sarkar M, Hull E, Simpson RJ, Moritz RL, Dunn R, Schachter H (1990) *Glycoconjugate J.* **7**:380.
- Sarkar M, Hull E, Nishikawa Y, Simpson RJ, Moritz RL, Dunn R, Schachter H (1991) *Proc Natl Acad Sci USA* **88**:234–38.
- Kumar R, Yang J, Larsen RD, Stanley P (1990) *Proc Natl Acad Sci USA* **87**:9948–52
- Hull E, Sarkar M, Spruijt MPN, Höppener JWM, Dunn R, Schachter H (1991) *Biochem Biophys Res Commun* **176**:608–15.
- Pownall S, Kozak CA, Schappert K, Sarkar M, Hull E, Schachter H, Marth JD (1992) *Genomics* **12**:699–704.
- Kumar R, Yang J, Eddy RL, Byers MG, Shows TB, Stanley P (1992) *Glycobiology* **2**:383–93.
- Fukada T, Iida K, Kioka N, Sakai H, Komano T (1994) *Biosci Biotechnol Biochem* **58**:200–1.
- Warren CE, Cummings L, Narasimhan S, Schachter H, Dennis JW (1992) *Glycobiology* **2**:488
- Burke J, Pettitt JM, Schachter H, Sarkar M, Gleeson PA (1992) *J Biol Chem* **267**:24433–40
- Burke J, Pettitt JM, Humphris D, Gleeson PA (1994) *J Biol Chem* **269**:12049–59.
- Paulson JC, Colley KJ (1989) *J Biol Chem* **264**:17615–18.
- Schachter H (1991) *Current Opinion in Structural Biology* **1**:755–65.
- Brockhausen I, Matta KL, Orr J, Schachter H (1985) *Biochemistry* **24**:1866–74.
- Paulsen H, Meinjohanns E (1992) *Tetrahedron Lett* **33**:7327–30.
- Paulsen H, Reck F, Brockhausen I (1992) *Carbohydr Res* **236**:39–71.
- Gwynne DI, Buxton FP, Williams SA, Garven S, Davies RW (1987) *Biotechnology* **5**:713–19.
- Punt PJ, Oliver RP, Dingemans MA, Pouwels PH, van den Hondel CA (1987) *Gene* **56**:117–24.
- Scharf SJ (1990) In *PCR Protocols: A Guide to Methods and Applications* (Innis MA, Gelfand DH, Sninsky JJ, White TJ, eds) San Diego, CA: Academic Press.
- Sambrook J, Fritsch EF, Maniatis T (1989) *Molecular Cloning: A Laboratory Manual*. Cold Spring Harbor, NY: Cold Spring Harbor Laboratory Press.
- Sanger F, Nicklen S, Coulson AR (1977) *Proc Natl Acad Sci USA* **74**:5463–67.

53. Möller G, Reck F, Paulsen H, Kaur KJ, Sarkar M, Schachter H, Brockhausen I (1992) *Glycoconjugate J* **9**:180–90
54. Palcic MM, Heerze LD, Pierce M, Hindsgaul O (1988) *Glycoconjugate J* **5**:49–63.
55. Nishikawa Y, Pegg W, Paulsen H, Schachter H (1988) *J Biol Chem* **263**:8270–81
56. Laemmli UK (1970) *Nature* **227**:681–85.
57. Cummings RD (1993) In *Glycobiology. A Practical Approach* (Fukuda M, Kobata A, eds.) pp 243–89 New York, NY: Oxford University Press.
58. Datti A, Orlacchio A, Siminovitch KA, Dennis JW (1992) *Anal Biochem* **206**:262–66
59. Ballance DJ, Buxton FP, Turner G (1983) *Biochem Biophys Res Commun* **112**:284–89.
60. Vella GJ, Paulsen H, Schachter H (1984) *Can J Biochem Cell Biol* **62**:409–17.
61. Brockhausen I, Carver J, Schachter H (1988) *Biochem. Cell Biol* **66**:1134–1151.
62. Velardo MA, Bretthauer RK, Boutaud A, Reinhold B, Reinhold VN, Castellino FJ (1993) *J Biol Chem* **268**:17902–7.
63. Chrispeels MJ (1985) *Plant Physiol* **78**:835–38.
64. Johnson KD, Chrispeels MJ (1987) *Plant Physiol* **84**:1301–8.
65. Szumilo T, Kaushal GP, Elbein AD (1986) *Biochem. Biophys. Res. Commun.* **134**:1395–403.
66. Vitale A, Chrispeels MJ (1984) *J Cell Biol* **99**:133–40.
67. Saunders G, Pickett TM, Tuite MF, Ward M (1989) *Trends in Biotechnol.* **7**:283–87.
68. Cumming DA (1991) *Glycobiology* **1**:115–30.
69. Cumming DA (1992) *Dev Biol Stand* **76**:83–94.
70. Furukawa K, Kobata A (1992) *Curr Opin Biotechnol* **3**:554–59.
71. Kobata A (1992) *Eur J Biochem* **209**:483–501.
72. Sarkar M, Schachter H (1992) *Glycobiology* **2**:483.